

AH-0822

Gas Detector

Characteristics

- The AH-0822 features advanced technology, high accurate detection, low power-consumption and fast reaction time. It can detect natural gas and propane gas. Built-in buzzer and LED indicator alert by sounding and flashing.
- Sounding and flashing in alarm status; the green LED is lit during monitoring and the red LED flashes in alarm status.
- Dual power input: 12VDC and 24VDC operation in the same unit. No adjustment is required.
- Optional 110VAC or 220VAC adaptor is available.

Approvals:  

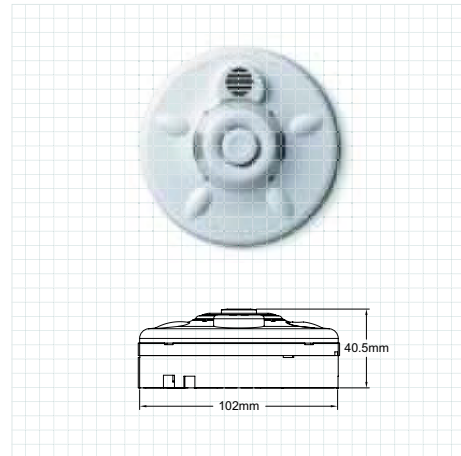

Specifications				
Model	AH-0822			
Approval	UL		CE	
Power Source	24V DC	12V DC	24V DC	12V DC
Standby Current	25~30mA	40~45mA	35~40mA	65~70mA
Alarm Current	40~70mA	50~75mA	75~90mA	90~105mA
Warm-up Period	5~8 minutes		about 35 seconds	
Sensitivity	0.021 ~ 0.300% (Propane) 0.050 ~ 0.714% (Methane)		0.050 ~ 0.300%	
Alarm Sound	85dB/3M and above		90dB/M and above	
Detection Type	Natural Gas & Propane Gas			
Ambient Temperature	-10°C ~ +55°C			
Dimensions	102 mm (Dia.) x 40.5 mm(H)			
Weight	About 130g			